



FIORA

OMG SIDELOADERS MAKER

Multidirectional sideloader S-SE SERIE LT 30-40



Multidirectional sideloader
Capacity: 3.000/4.000 Kg

The FIORA/OMG multidirectional sideloader S - SE Series can be used to transport and to store palletised and long materials. It can therefore operate smoothly in warehouses organized with pallet-holding or cantilever racking system. The driver, sitting comfortably in the cabin and protected by the sturdy safety roof, can operate and have full control of all the functions of the sideloader through a simple movement of the joystick and the steering wheel.

Ergonomics and multidirectional features - Speed and space recovery

The multidirectional drive offers 12 different steering programmes. The driver can select the most appropriate and safe drive depending on the transported load and on the working environment, driving the sideloader in full safety.

The position of each wheel is electronically controlled by encoders. The sideloader can quickly change direction by driving from front-way to side-way, from diagonal to 360° carousel.

STURDY, SAFE AND RELIABLE: THESE ARE THE FEATURES OF THE FIORAIOMG MULTIDIRECTIONAL SIDELOADER.

The use of solid and reliable materials, the accuracy in their processing, the attention to details, make each FIORAIOMG sideloader versatile, agile and responsive, as well as extremely safe and pleasant to drive, even in severe working conditions.



Balanced articulated chassis divided into two parts (mechanical compensation) to work on slightly unlevelled floors and keep the constant contact of the wheels to the ground, improving the stability of the machine.



Three phase electric AC motors in alternating current in Open Can-Bus to enhance performance, reduce consumption of the battery and reduce maintenance costs.



Multifunctional proportional joystick, Can-Bus wired for a sensitive and accurate control of the movements of the machine.
Large colour LCD display tilted towards the operator with well visible function keys.



Logic and rational arrangement of components within the housings so as to ease access and for a quick maintenance reducing the time required for intervention, machine stops and consequent costs.



Wide fork carriage and hydraulic fork spreader allow to carry long materials, stabilizing the load.



STAND UP CABIN



LATERAL/ DIAGONAL SEAT CABIN



FRONT CABIN

Front, diagonal or lateral drive cabin with the operator sitting or standing in order to meet the work requirements of each single customer and to adapt the sideloader to the working environment.



POLYURETHANE



CUSHION



SUPER ELASTIC

Large diameter wheels: polyurethane, cushion rubber or Super Elastic rubber: to operate within warehouses on industrial floorings or outside on asphalt. Electromagnetic brakes ensure fast response to the stop command.

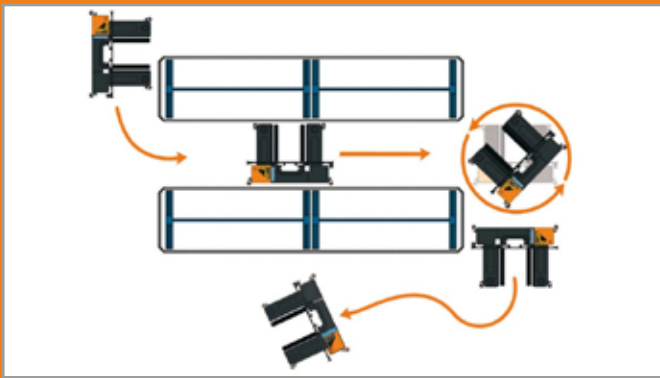

MULTIDIRECTIONAL BATTERY ELECTRIC SIDELoader

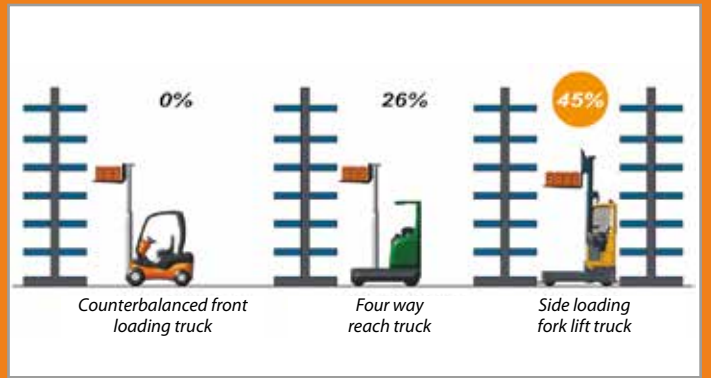

SPACE SAVING



TECHNICAL FEATURES:

- **Ergonomic cab** standard with the operator seated or standing, wide visibility in all directions and protection.
- **Ergonomic and comfortable driver seat**, fully adjustable vertically, horizontally and in rigidity, lined in hypoallergenic and wear resistant material.
- **Multifunctional proportional joystick** for the control of the movements of the mast and the driving selection.
- **Large LCD colour display** tilted towards the operator to allow the best view angle, with information on the machine status.
- **Electrical systems in open Can-Bus** with constant self-diagnosis of the machine functions and trouble-shooting.
- **Ignition through customised PIN code.**
- **Articulated chassis** divided into two parts (mechanical compensation) to work also on slightly unlevelled floor.
- **Three phase AC motors** (alternating current) to enhance the performance of the machine and reduce maintenance costs.
- **Manufactured with quality materials** and precision in mechanical processing for high reliability and duration of the sideloader and to constantly offer the best performance throughout time.
- **360° pivoting** of all the wheels for a multidirectional drive and manoeuvrability in all directions.
- **Energy recovery electronic brakes** to stabilise the draw of electricity from the battery and optimize both performance and duration.
- **Low maintenance and ease of access to the compartments** for rapid and precise interventions, thus reducing halts and costs due to machine stops.
- **Possibility to customise the sideloader with countless accessories**, in accordance to one's working requirements.



Wood

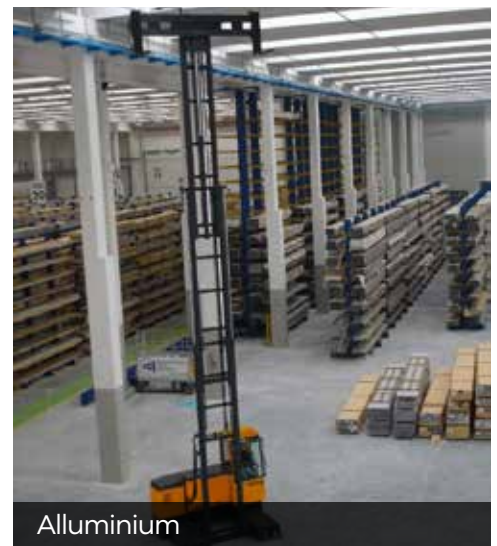

Alluminium



Steel&Metals



Industria